

















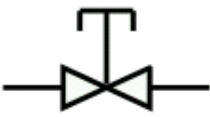







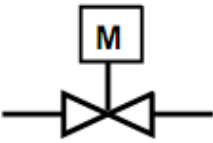

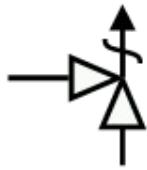



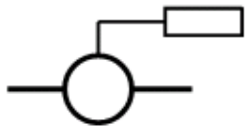

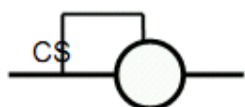

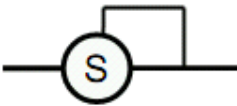

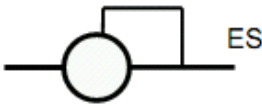

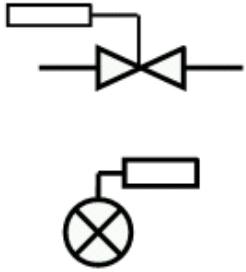

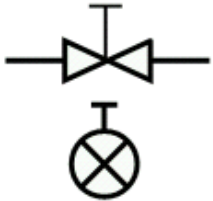

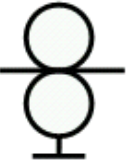

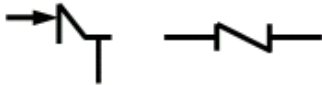



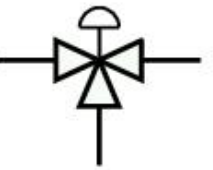





الرمز	نموذج	العنصر
		High side float valve
		low side float valve
		gate valve
		Globe valve
		Lock shield valve

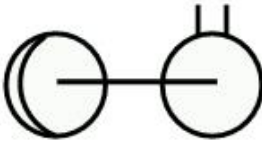

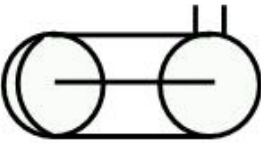

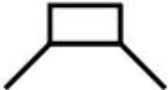

الرمز	نموذج	العنصر
		Plug
		Pressure regulating valve
		Pressure- reducing valve
		Motor operated valve



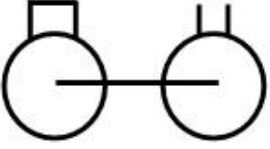

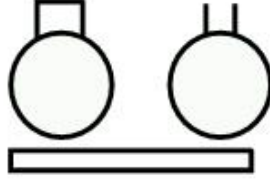

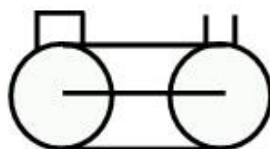

الرمز	نموذج	العنصر
		Relief valve
		Solenoid valve
		Valve, evaporator pressure regulating, Thermostatic throttling type
		Valve, compressor suction pressure limiting, Thermostatic throttling type (compressor side)
		Valve, evaporator pressure regulating, Thermostatic

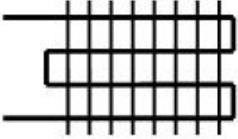





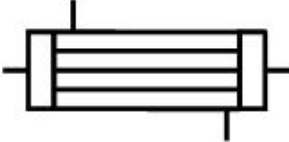

الرمز	نموذج	العنصر
		<p>Valve, evaporator pressure regulating, throttling type (evaporator side)</p>
		<p>Thermostatic expansion valve</p>
		<p>Hand expansion valve</p>
		<p>Constant pressure valve</p>
		<p>Check valve</p>

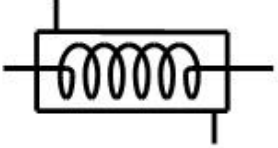

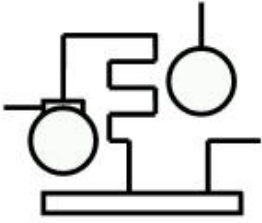

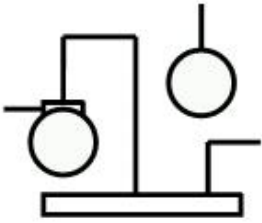

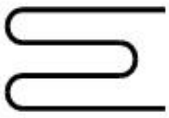

الرمز	نموذج	العنصر
		2-way automatic valve
		3-way automatic valve
		Air line valve
		Air eliminator

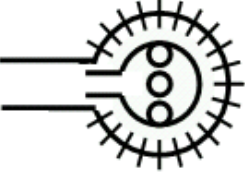
الرمز	نموذج	العنصر
		<p>Motor Compressor, rotary, enclosed crankcase Direct connection</p>
		<p>Motor Compressor, rotary, Direct connection Sealed crankcase</p>
		<p>Compressor, open crankcase reciprocating , belted</p>
		<p>Compressor, open crankcase reciprocating , direct connection</p>



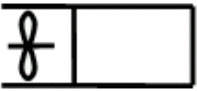

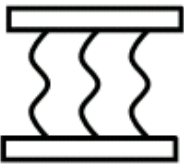

		<p>Motor Compressor, enclosed crankcase reciprocating , direct connection</p>
		<p>Motor Compressor, open crankcase, reciprocating , belted</p>
		<p>Motor Compressor, sealed crankcase, reciprocating , direct connection</p>







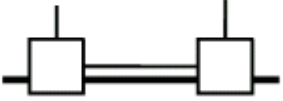
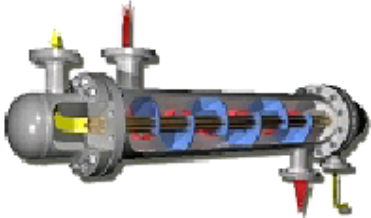



الرمز	نموذج	العنصر
		<p>Finned air cooled condenser, static</p>
		<p>Finned air cooled condenser, forced air</p>
		<p>Evaporative Condenser</p>
		<p>Water cooled condenser, Shell and tube</p>



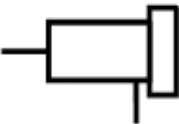



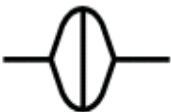

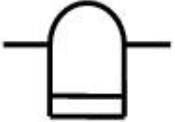

الرمز	نموذج	العنصر
		<p>Water cooled condenser, Shell and coil</p>
		<p>Air cooled condensing unit</p>
		<p>Water cooled condensing unit</p>
		<p>Coil</p>

الرمز	نموذج	العنصر
		<p>Finned circular evaporator, ceiling type</p>
		<p>Natural convection, Finned type Evaporator</p>
		<p>Forced convection Evaporator</p>
		<p>Plate coil Evaporator</p>

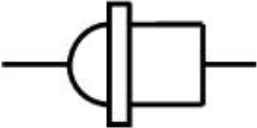

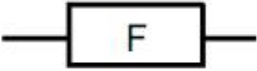







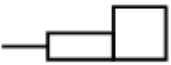

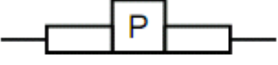

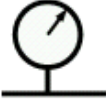
٤,٢ - رموز بعض عناصر التبريد

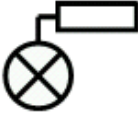
الرمز	نموذج	العنصر
		Immersion cooling unit
		Cooling tower
		Heat exchanger
		Sight glass





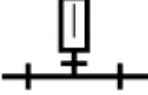



الرمز	نموذج	العنصر
		Drier
		Strainer
		Strainer and drier
		Filter and strainer
		Line Filter

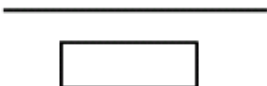

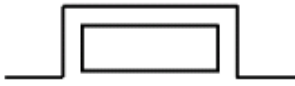
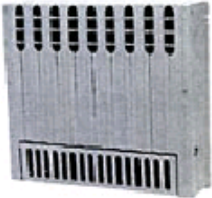
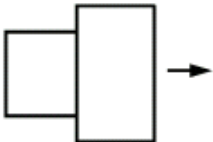

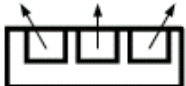

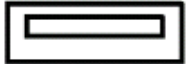
الرمز	نموذج	العنصر
		Scale trap
		Basket trap
		Boiler return
		Float trap
		Traps, thermostatic





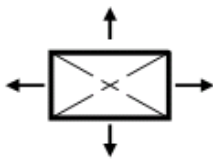

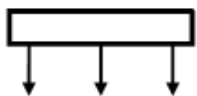
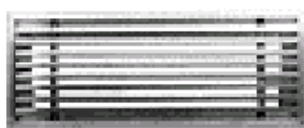

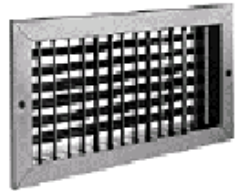
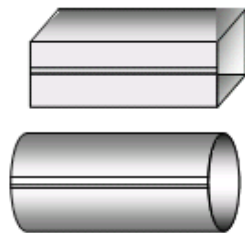
٧,٢ - رموز بعض أجهزة التحكم والقياس

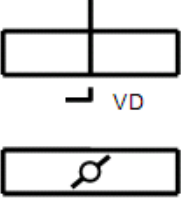
الرمز	نموذج	العنصر
		Pressure switch
		Dual pressure switch
		gauges
		Thermostat with remote bulb
		Self contained thermostat
		Thermal bulb
		Thermometer

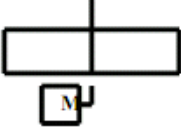
٨,٢ - رموز بعض عناصر التكييف والتهوية

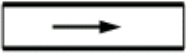
الرمز	نموذج	العنصر
		
		
		Unit heater (propeller)
		Unit heater (centrifugal)
		Unit ventilator

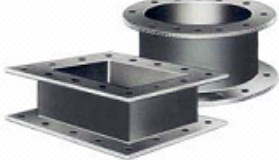
الرمز	نموذج	العنصر
		circular ceiling diffuser
		Square ceiling diffuser
		linear diffuser
		Floor register
<div style="border: 1px solid black; padding: 2px; width: fit-content; margin-bottom: 5px;">12 x 20</div> <div style="border: 1px solid black; padding: 2px; width: fit-content;">Ø20</div>		Duct

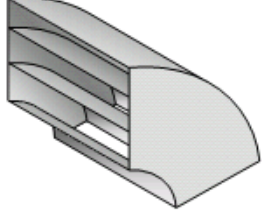
الرمز	نموذج	العنصر
		Manual volume damper
		Automatic volume damper
		Direction of flow
		Flexible connection
		Turning vanes

