



Ministry of Higher Education and  
Scientific Research  
Northern Technical University  
Technical College of Engineering, Mosul



# Educational bag

scientific department: Power Mechanics engineering techniques

Course Name: Electrical technology

Stage/Level: First

Semester: First

**academic year: 2025-2026**





Course Name:	Electrical technology			
Department:	Power Mechanics engineering techniques			
College:	<b>Engineering Technical College/Mosul</b>			
Stage/Level:	<b>First</b>			
Semester:	<b>First</b>			
No. of hours per week:	Theoretical	3	Practical	2
Units:	<b>4</b>			
Code:	<b>TEMO 101</b>			
Types of course	Th	yes	Pr	Both
Is there a counterpart to the course in other departments?	<b>Yes</b>			
Name of counterpart rapporteur (if any)	<b>Electrical engineering techniques, Computer engineering techniques, Medical engineering techniques</b>			
Department:				
Code:				
<b>Lecturer information</b>				
Name of course teacher:	<b>Safwan Assaf Hamoodi</b>			
The scientific title:	<b>Assist prof.</b>			
Year of obtaining the title:	<b>2022</b>			
Academic certificate:	<b>Master</b>			
Year of obtaining academic certificate	<b>2009</b>			
Number of years of experience (teaching)	<b>15</b>			

## General description of the course

---

The major aims student is prepared to study the different calculations in AC and DC circuits and to learn about the different theories for studying these calculations. The graduate will also be familiar with modern applications in the field of specialization.

---

## General goals

---

**1-Understanding the Fundamentals:** The primary objective of a DC circuits course is to provide students with a solid foundation in the fundamental principles of direct current (DC) circuits. This includes concepts such as voltage, current, resistance, Ohm's law, power, and energy.

**2-Analyzing Circuit Components:** Students will learn how to analyze and work with various circuit components. They will understand their behavior in DC circuits and be able to calculate their effects on voltage, current, and power.

**3-Circuit Laws and Theorems:** Students will become familiar with important laws and theorems governing DC circuits, including Ohm's law, Kirchhoff's laws (KCL and KVL), Thevenin's theorem, Norton's theorem, and maximum power transfer theorem. They will gain proficiency in applying these principles to solve complex circuit problems.

**4-Circuit Simulation and Design:** The course may involve introducing students to circuit simulation software. They will learn how to use simulation tools to analyze and design DC circuits, verify their calculations, and gain practical insights into circuit behavior.

---

## Private goals

---

To understand:

- **Fundamental Knowledge:** Students will acquire a solid understanding of the fundamental concepts and principles of direct current (DC) circuits, including voltage, current, resistance, power, and energy.
  - **Circuit Analysis Skills:** Students will develop the ability to analyze DC circuits using various techniques such as applying Kirchhoff's laws, performing nodal and mesh analysis, and utilizing circuit theorems like Thevenin's and Norton's theorem. They will gain proficiency in solving complex circuit problems and calculating circuit parameters.
  - **Circuit Design and Simulation:** Students will be able to design and simulate DC circuits, using appropriate components and considering design constraints. They will learn to use circuit simulation software to verify their designs, analyze circuit performance, and troubleshoot circuit issues.
-

## Behavioral objectives or learning outcomes

- **Laboratory Skills:** Through hands-on laboratory experiments, students will develop practical skills in building, testing, and troubleshooting DC circuits. They will become proficient in using measuring instruments, interpreting experimental data, and ensuring safety precautions while working with electrical circuits.
- **Critical Thinking and Analysis:** The course will promote critical thinking and analytical skills among students. They will learn to evaluate different circuit solutions, analyze circuit behavior, and make informed decisions based on their understanding of DC circuits.
- **By the end of the course,** students will possess a comprehensive knowledge of DC circuits, enabling them to analyze, design, and troubleshoot a wide range of electrical circuits. They will be prepared for further studies in electrical engineering or related fields and equipped with skills that can be applied in professional practice

## Prerequisites

- Registration in the electrical technology course, first and second semester

<b>Behavioral goals or basic learning outcomes</b>		
<b>No.</b>	<b>Detailing the behavioral goal or educational outcome</b>	<b>Evaluation mechanism</b>
<b>1</b>	<b>Symbols and abbreviations, electric circuit and its elements.</b>	<b>Presentation + homework</b>
<b>2</b>	<b>Ohm's law, Kirchhoff's laws.</b>	<b>Presentation + homework</b>
<b>3</b>	<b>Series resistors and voltage division, parallel resistors and current division.</b>	<b>Presentation + homework</b>
<b>4</b>	<b>Wye-delta transformation, source transformations.</b>	<b>Presentation + homework</b>
<b>5</b>	<b>Mesh analysis.</b>	<b>Presentation + homework</b>



<b>6</b>	<b>Nodal analysis.</b>	<b>Presentation + homework</b>
<b>7</b>	<b>Superposition's theorem.</b>	<b>Presentation + homework</b>
<b>8</b>	<b>Thevenin's theorem.</b>	<b>Presentation + homework</b>
<b>9</b>	<b>Norton's theorem</b>	<b>Presentation+ homework</b>



## TEACHING STYLES (SELECT A VARIETY OF TEACHING STYLES TO SUIT STUDENT NEEDS AND COURSE CONTENT)

Method	JUSTIFICATIONS FOR SELECTION
1. Attendant education	TEACHING STUDENTS THE BASICS OF THE ACADEMIC SUBJECT
2. E-learning	TEACHING STUDENTS TO USE COMPUTERS AND SOME SOCIAL MEDIA
3. Discussion	TEACHING STUDENTS TO PARTICIPATE IN THE ACADEMIC SUBJECT
4. Seminars	TEACHING STUDENTS TO GIVE LECTURES
5. Teaching inside the laboratory	INTRODUCING STUDENTS TO THE PRACTICAL ASPECT OF THE SUBJECT

First chapter							
Chapter title	Hours		Chapter title	Subtitle	Teaching method	Techniques	Measurement methods
Time distribution	Theoretical	Practical					
1 <sup>st</sup> , 2 <sup>nd</sup> weeks	3	1	<b>Symbols and abbreviations, electric circuit and its elements.</b>		Lectures	Presentation, explanation, questions and answers, discussion	Quiz
3 <sup>rd</sup> week	2	2	<b>Ohm's law, Kirchhoff's laws.</b>		Lecture	Presentation, explanation and discussion	seminar
4 <sup>th</sup> week	2	2	<b>Series resistors and voltage division, parallel resistors and current division.</b>		Lecture	Presentation, explanation and discussion	seminar
5 <sup>th</sup> week	2	2	<b>Wye-delta transformation, source transformations</b>		Lecture	Presentation, explanation and discussion	seminar
6 <sup>th</sup> , 7 <sup>th</sup> weeks	3	2	<b>Mesh analysis.</b>		Lectures	Presentation, explanation and discussion	Reports
Second chapter							
8 <sup>th</sup> week	2	2	Nodal analysis		Lecture	Presentation, explanation and discussion	Mid term exam
9 <sup>th</sup> week	2	2	Superposition theorem		Lecture	Presentation, explanation and discussion	seminar



10 <sup>th</sup> week	2	2	Norton theorem		Lecture	Presentation, explanation and discussion	Quiz
11 <sup>th</sup> week	2	2	Thevenins Theorem		Lecture	Presentation, explanation and discussion	Report
12 <sup>th</sup> week	2	2	Max. power theorem		Lecture	Presentation, explanation and discussion	seminar
13 <sup>th</sup> week	2	2	Ac Circuit		Lecture	Presentation, explanation and discussion	seminar
14 <sup>th</sup> week	2	2	Capacitor		Lecture	Presentation, explanation and discussion	Quiz
15 <sup>th</sup> week	2	2	inductance		Lecture	Presentation, explanation and discussion	Report

# Scientific content

## Approved measurement map

Educational content	Chapter titles	Relative importance	Behavioral goals					Number of paragraphs	
			percentage	Knowledge	Understanding	Application	Analysis		Evaluation
1 <sup>st</sup> -2 <sup>nd</sup> weeks		5%		2%	1%				3
3 <sup>rd</sup> week		5%		2%	1%				3
4 <sup>th</sup> week		5%		2%	1%				2
5 <sup>th</sup> week		10%		4%	2%				4
6 <sup>th</sup> -7 <sup>th</sup> weeks		10%		4%	2%				4
8 <sup>th</sup> week		5%		2%	1%				2
9 <sup>th</sup> week		10%		4%	2%				4
10 <sup>th</sup> week		5%		2%	1%				2
11 <sup>th</sup> week		5%		2%	1%				2
12 <sup>th</sup> week		10%		4%	2%				4
13 <sup>th</sup> week		10%		4%	2%				4
14 <sup>th</sup> week		10%		4%	2%				4
15 <sup>th</sup> week		10%		4%	2%				10
Sum		100%		40%	10%				

Lecture number:	1 <sup>st</sup> , 2 <sup>nd</sup> and 3 <sup>rd</sup> weeks
Lecture title:	Electrical technology
Lecturer name:	Safwan Assaf
Target group :	1 <sup>st</sup> stage
General objective of the lecture:	The student understands the basic concepts of Electrical technology
Behavioral objectives or learning outcomes:	<ul style="list-style-type: none"> <li>• Explain the principles that underlie the ability of various natural phenomena to deliver solar energy.</li> <li>• outline the technologies that are used to harness the power of solar energy</li> <li>• discuss the positive and negative aspects of solar energy in relation to natural and human aspects of the environment.</li> </ul>
Facilitation strategies used	Whiteboard + data show
Acquired skills	Learn about the Electrical technology
Approved measurement methods	Quiz+ Seminar+ Assignments

**Symbols and Abbreviations:**

Quantity	Symbol	Unit	Unit Symbol
Resistance	R	ohm	$\Omega$
Capacitance	C	farad, microfarad, picofarad	F, $\mu$ f, pf
Inductance	L	henry	H
Impedance	Z	ohm	$\Omega$
Resistivity	$\rho$	ohm metre	$m\Omega -$
Conductivity	$\sigma$	Siemens per metre	S/m
Admittance	Y	siemens	S
current	I	ampere, milli ampere, microampe	A , mA , $\mu$ A
Potential	v	volt, milli volt, kilovolt	V , mV, KV
Frequency	f	hertz, kilohertz, megahertz	Hz , KHz , MHz
Power	P	watt, kilowatt, megawatt	W, KW , MW
Energy	w	joule, watt hour	J , Wh
Force	F	Newton	N
Efficiency	$\eta$	unitless	

**Abbreviations for Multiples and Submultiples:**

T	tera	$10^{12}$
G	giga	$10^9$
M	mega	$10^6$
K	kilo	$10^3$
d	deci	$10^{-1}$
c	centi	$10^{-2}$
m	milli	$10^{-3}$
$\mu$	micro	$10^{-6}$
n	nano	$10^{-9}$
p	pico	$10^{-12}$

### **International System of Units:**

The international system of units known as SI. The SI unit has six fundamental units. The six units of SI system along with their names and units are given in the table below:

Quantity	Symbol	Unit	Abbreviation
length	l	metre	m
mass	m	kilogram	Kg
time	t	second	S
Electric current	I	ampere	A
temperature	T	kelvin	K
luminous intensity	Em	Candela	Cd

### **Electric circuit and its elements:**

An electric circuit or electric network is a collection of electrical elements interconnected. In some specified way so that a closed path is available for the current to flow. The two terminals a and b of a source of electrical energy are connected by wires to resistor, inductors, capacitors or other solid state

devices. The three basic circuit elements are resistance, inductance and capacitance which have two terminals. More complicated circuit elements may have two terminals such as transistors.

**Resistance:** is the first circuit element used to represent energy dissipation as heat or radiant energy.

**Inductance:** is the second circuit element used to represent the energy stored in a magnetic field and is measured in henrys.

**Capacitance:** is the third circuit element used to represent charge storage and consequently, energy stored in electric field and is measured in farad. The circuit symbols for a resistance, inductance and capacitance are shown below.

Variable circuit element is indicated by indicated by placing an arrow across the symbol of the element.

### **Classification of Elements:**

The circuit element can be classified as:

- 1- Linear element: if the voltage – current characteristic is a straight line
- 2-Nonlinear element: if the relationship between voltage and current is not a straight line.
- 3-Passive element: is an element containing no sources of energy such as resistance, inductance and capacitance.
- 4-Active element: is an elements having internal energy source such as generator, battery.

### **Voltage and current sources:**

The two very important sources (active element) are:

- 1-independent voltage source
- 2-independent current source.

1-An independent voltage source is a two terminal element such as a battery or a generator that maintains a voltage between its terminals. The voltage is independent of the current through the element. The symbol for a voltage source is shown below. The terminal a is higher potential than b.

The voltage  $v$  may be time varying or it may be constant. If it is constant another symbol that is its terminals as shown in above fig.

2-An independent current source is a two terminal element through which a current flow. The current is independent of the voltage across the element. The symbol for an independent current source is shown below; the direction of the current is indicated by the arrow.

### **Dependent Sources:**

A dependent voltage source is one whose terminal voltage depends on, or is controlled by voltage or current existing at some other place in the circuit.

A dependent current source is one whose current is dependent on voltage or current existing elsewhere in the circuit.

**Ex.** For the circuit shown, find the voltage  $v$  across the 500 resistor .

From the left part , we have

$$I = 5/2k$$

$$= 2.5mA$$

$$I = 40I = 40 * 2.5mA = 0.1 A$$

$$V = -500 * 0.1 = -50 v$$

The minus sign means the voltage in the opposite direction.

### Connection of resistances:

There are two types of connections:

1-series connection  $R_t = R_1 + R_2 + R_3 + R_4 + \dots$

2-parallel connection  $1/R_T = 1/R_1 + 1/R_2 + 1/R_3 + 1/R_4 + \dots + 1/R$

### Delta – Star and Star- Delta Transformation:

There are some networks in which the resistances are neither in series nor in parallel. Familiar case is a three terminal network e.g. delta network or star network. In such situations it is not possible to simplify the network by series and parallel circuit rules.

However, converting delta network into star and vice-versa, often simplifies the network and makes it possible to apply series – parallel circuit techniques.

### Delta – Star Transformation:

The above fig. shows three resistors  $R_1, R_2$  &  $R_3$  connected in a closed mesh or delta to three terminals A, B & C. It is possible to replace these delta connected resistors by three resistors  $R_a, R_b$  &  $R_c$  connected respectively between the same terminals A, B & C and a common point s, such an arrangement is said to be star connected.

$$R_a = \frac{R_2 R_3}{R_1 + R_2 + R_3}$$
$$R_b = \frac{R_3 R_1}{R_1 + R_2 + R_3}$$
$$R_c = \frac{R_1 R_2}{R_1 + R_2 + R_3}$$

$$R_c = \frac{R_1 R_2}{R_1 + R_2 + R_3}$$

**Star- Delta Transformation:**

To conform star connection into delta connection , we flow the following rules.

$$R_1 = R_b + R_c + \frac{R_b R_c}{R_a}$$

$$R_2 = R_c + R_a + \frac{R_c R_a}{R_b}$$

$$R_3 = R_a + R_b + \frac{R_a R_b}{R_c}$$

**Ex.** For the circuit shown determine the current delivered by the source.  
 The network consisting of resistances 20, 30 &50 forms a delta with corners A, B&D. these delta can be replaced by equivalent star connected resistances R1, R2 &R3

$$\Omega = 10R_1 = \frac{20 * 50}{30}$$

$$20+30+50$$

-----

$$20+30+50$$

-----

$$20+30+50$$

$$R_{NC} = (6+24) // (15+5)$$

$$= 12 \text{ ohm}$$

$$20*30$$

$$\Omega = 6 \quad R_2 = \text{-----}$$

$$20*50$$

$$\Omega = 15 \quad R_3 = \text{-----}$$

$$220$$

$$= 10 \text{ A Current delivered by source } I = \text{-----}$$

$$22$$

### Ohm's

#### law:

The ratio of the potential difference (v) between the ends of a conductor to the current (I) flowing between them is constant, provided the temperature do not change i.e

$$V/I = \text{constant} = R$$

Where R is the resistance of the conductor between the two points

If the voltage between points A and B is V volt and current flowing is I ampere , then V/I will be

Constant and equal to R.

If the voltage is doubled up the current will also doubled up so that the ratio V/I remains constant.

If the voltage is measured in volts and current in amperes, then resistance will be in ohms.

The following points may be noted about Ohm's law:

1- Ohm's law is true for metal conductors at constant temperature, if the temperature changes, Ohm's law is not applicable.

2- Ohm's law is true for d.c. circuits. It is not generally valid for a.c. circuits.

3- Ohm's law can be expressed in three forms:

$$I = V/R \quad V = IR \quad R = V/I$$

4- If Ohm's law is expressed graphically (taking voltage along the Y-axis and current along the X-axis),

the slope of the graph will give the resistance.

**Ex.1:** For the circuit shown, find values for: 1- resistance  $R_3$     2- applied voltage

$$I_1 = I_2 + I_3$$

$$I_2 = I_1 - I_3$$

$$= 250 - 100 = 150 \text{ mA}$$

$$\begin{aligned} \text{p.d across } R_2 &= I_2 * R_2 \\ &= 150 \text{ mA} * 40 = 6 \text{ volt} \end{aligned}$$

Since 6 volt is applied at points B and C and is therefore across  $R_3$

$$R_3 = V/I_3 = 6/100 \text{ mA} = 60 \text{ ohm}$$

As  $R_1$  &  $R_4$  are both series components, with the circuit current of 250 mA passing through them both

$$E = 250 \text{ mA} * (120 + 56) = 44 \text{ volt.}$$

$$\text{The applied voltage} = 44 + 6 = 50 \text{ volt.}$$

Another method:

$$R_t = \left\{ \frac{R_2 * R_3}{R_2 + R_3} \right\} + R_1 + R_4$$

$$I = 250 \text{ mA}$$

$$E=I \cdot R_t = 50 \text{ volt}$$

**Ex.2:** For the circuit shown determine :

- 1-The total current.
- 2-the current through the 100 ohm resistor.
- 3-The current through the 300 ohm resistor.
- 4-The p.d across the 100 ohm resistor.
- 5-The p.d across the 50 ohm resistor.

**Sol.**

$$R_{bc} = (100 \cdot 300) / (100 + 300) = 75 \text{ ohm}$$

$$R_t = 75 + 50 = 125 \text{ ohm}$$

$$1- I_t = 50 / 125 = 400 \text{ mA}$$

$$2- I_2 = R_3 / (R_2 + R_3) \cdot I_t \\ = 300 / (100 + 300) \cdot 400 \text{ mA} = 300 \text{ mA}$$

$$3- I_3 = R_2 / (R_2 + R_3) \cdot I_t \\ = 100 / (100 + 300) \cdot 400 \text{ mA} = 100 \text{ mA}$$

$$4- \text{p.d across } R_2 = 300 \text{ mA} \cdot 100 = 30 \text{ v}$$

$$5- \text{p.d across } R_1 = E - V_2 = 50 - 30 = 20 \text{ volt.}$$

**Kirchhoff s law:**

First law (Kirchhoff current law ): the total current flowing towards a node is equal to the total current flowing away from that node, i.e the algebraic sum of the currents flowing towards a node is zero.

Thus at node c in the fig shown  $I_1 + I_2 = I_3$

$$I_1 + I_2 - I_3 = 0$$

$$\text{Or } \sum I = 0$$

Where  $\sum$  represent the algebraic sum

A node of a network is defined as the junction point of two or more branches of that network such as point c in the above fig. some conductors have currents leading to point c whereas some have currents leading away from point c.

Assuming the incoming currents to be positive and the outgoing currents negative .

Second law ( Kirchhoff voltage law): In a closed circuit , the algebraic sum of the products of the current and the resistance of each part of the circuit is equal to the resultant e.m.f in the circuit. Thus for the closed circuit involving  $E_1, E_2, R_1 \& R_2$  in the above fig.

$$E_1 - E_2 = I_1 R_1 - I_2 R_2$$

And for the mesh involving  $E_2, R_2 \& R_3$

$$E_2 = I_2 R_2 + I_3 R_3$$

In general  $\sum E = \sum IR$

**Ex.** Using Kirchhoff's law, calculate the current in each branch of the network shown

Applying Kirchhoff's law to the left part of the circuit we get

$$\begin{aligned} 6 &= 2I_1 + 10(I_1 + I_2) \\ &= 12I_1 + 10I_2 \text{-----(1)} \end{aligned}$$

Similarly, for the outer closed circuit we get

$$\begin{aligned} 6 - 4 &= 2I_1 - 3I_2 \\ 2 &= 2I_1 - 3I_2 \text{-----(2)} \end{aligned}$$

Solving eqs. 1 & 2 we get

$$I_1 = 0.679 \text{ A}$$

$$I_2 = -0.215 \text{ A}$$

$$I_3 = I_1 + I_2$$

$$= 0.679 - 0.215 = 0.464 \text{ A}$$

**Maxwell (mesh) current method:**

In this method, Kirchhoff voltage law is applied to a network to write mesh equations in terms of mesh currents instead of branch currents.

Each mesh is assigned a separate mesh current. This mesh current is assumed to flow clockwise around the elements of the mesh without splitting at branch currents can easily determined.

Maxwell mesh current method consist of following steps:

1- Each mesh is assigned a separate mesh current, all mesh current are assumed to flow in clockwise direction.

2- If two mesh currents are flowing through a circuit element, the actual current in the circuit element is the algebraic sum of the two. Thus in the fig. shown, there are two mesh currents  $I_1$  &  $I_2$  flowing in  $R_2$ . If we go from B to D current is  $(I_1 - I_2)$

And if we go in the other direction( from D to B) , current is  $(I_2 - I_1)$ .

3- Kirchhoff voltage law is applied to write equation for each mesh in term of mesh

Currents. Remember while writing mesh equations, rise in potential is assigned

+ve sign and fall in potential negative sign.

4- If the value of any mesh current out to be negative in the solution , it means that

True direction of that mesh current is anticlockwise , i.e opposite to that assumed

Clockwise direction.

**Ex.** In the network shown, find the magnitude and direction of each branch current by

Mesh current method.

For mesh(1)

$$3I_1 + 6(I_1 - I_2) = 51$$

$$9I_1 + 6I_2 = -6 \text{ -----(1)}$$

$$12I_2 + 6(I_2 - I_1) = -6$$

$$-6I_1 + 18I_2 = -6 \text{ -----(2)}$$

Solving eqs. 1&2 we get,

$$I_1 = 7A \quad \& \quad I_2 = 2A$$

**Nodal analysis :**

The nodal analysis is used for determining the branch currents in the circuit. In this method, one of the nodes is taken as the reference node. The potentials of all the points in the circuit are measured with respect to this reference node. If this potential can be found, each branch current can be determined because the voltage across each resistor will be known.

For the circuit shown, at point (node) B we have

$$I_1 + I_2 = I_3$$

Voltage drop across R1 is  $E_1 - V_b$

$$I_1 = (E_1 - V_b) / R_1$$

Voltage drop across R3 is  $E_2 - V_b$

$$I_2 = (E_2 - V_b) / R_3$$

$$I_3 = V_b / R_2$$

$$\frac{E_1 - V_b}{R_1} + \frac{E_2 - V_b}{R_3} = \frac{V_b}{R_2}$$

$$V_{12} = V_1 - V_2$$

$$V_{23} = V_2 - V_3$$

$$V_{13} = V_1 - V_3$$

**Superposition Theorem:**

In a linear network containing more than one source of e.m.f. The resultant current in any branch is the algebraic sum of the currents that would be produced by each e.m.f acting alone , all other sources of e.m.f being replaced by their internal resistances.

Notes: the internal resistance of the voltage source is zero(short circuit).

the internal resistance of the current source is very large( open circuit).

**Ex:** Find the current in 2 ohm resistor using superposition theorem

For fig.2, 40 v source is replaced by s.c so that e.m.f of 35v is acting alone

$$2 \times 4$$

$$R_t = 4.33 \Omega \quad R_{t1} = 3 + \dots$$

$$2 + 4$$

$$I_1 = 35 / 4.33 = 8.08 \text{ A}$$

$$I_3 = 8.08 \times (4 / (2 + 4)) = 5.39 \text{ A}$$

For fig.3, 35v is replaced by s.c so that e.m.f of 40v is acting alone.

$$3 \times 2$$

$$R_{t2} = 4 + \dots = 5.2 \text{ ohm}$$

$$3 + 2$$

$$I_2 = 40 / 5.2 = 7.69 \text{ A}$$

$$3$$

$$I_3 = 7.69 \times \dots = 4.61 \text{ A}$$

$$3 + 2$$

$$I_3 = I_3 + I_3$$

$$=5.39+4.61 =10\text{A}$$

$$I1=I1-I1$$

$$=8.08-3.08 =5\text{A}$$

$$I2=I2-I2$$

$$=7.69-2.69=5\text{A}$$

$$I3=I1+I2=5+5=10$$

### **Thevenin Throrem:**

Any two terminal network ,however complex ,can be replaced by a single source (called Thevenin throrem) in series with single resistance (called Thevenin resistance).

Thevenin voltage is the voltage between A and B with removed.

Thevenin resistance is the resistance between A and B with removed and all the sources in the circuit are replaced by their internal resistances.

Once Thevenin equivalent circuit is obtained, the current through any load connect across AB can be obtained.

**Ex:** Determine the current and power loss in 50 ohm resistor shown in the following circuit by Thevenin theorem.

1- Remove the 50 ohm resistor, the circuit become as shown in fig.1

2- To find Eth from fig.2

$$E_{th}=V_{10}$$

$$I_{10} =100/50=2\text{A}$$

$$E_{th}=V_{10}$$

$$I_{10} =100/50=2\text{A}$$

$$V_{10} =2*10=20\text{v}$$

3- To find  $R_{th}$ , replace 100v source by s.c the circuit becomes as shown in fig.2

$$R_{th} = (20+20) // 10 + 20 + 20 \\ = 48 \text{ ohm}$$

4- Thevenin circuit becomes as shown in fig.3

$$I_{50} = 20 / (48 + 50) = 0.2 \text{ A}$$

$$P = I^2 * R \\ = 0.2^2 * 50 = 2 \text{ W}$$

In the case of dependent source  $R_{th} = E_{th} / I_{s.c}$

### **Maximum power transfer:**

Maximum power transfer from the source to the load occurs when the load resistance is equal to the internal resistance of the source. Since Thevenin equivalent circuit is similar to the circuit of the ideal voltage source which is consist of voltage source in series with the internal resistance of the source. So in the case of Thevenin circuit, maximum power transfer occurs when the internal resistance of the source is equal to the Thevenin resistance.

### **Norton s Theorem:**

Any network, having two terminals A and B, can be replaced by a current source ( $I_n$ ) in parallel with a resistance  $R_n$ . current source ( $I_n$ ) is equal to the current that would flow through AB when A and B are short circuit. The resistance  $R_n$  is the resistance between A and B with load removed and all the sources in the circuit are replaced by their internal resistances.

**Ex.:** Find the current in 5 ohm resistor shown in the following circuit by Norton's theorem.

1- Remove the 5 ohm resistor, the circuit becomes as shown in fig.1

2- To find  $R_n$  replace the 10 ohm the 10A source by o.c the circuit becomes as shown in fig.2

$$R_n = \frac{(2+8)(6+4)}{(2+8)+(6+4)} = 5 \text{ ohm}$$

3- To find  $I_n$ , replaced the 5 ohm resistor by s.c as shown in fig. 3

$$I_n = I_{s.c} = I_2$$

$$I_2 = 10 \cdot 8 / (8+2) = 8A$$

4- Norton circuit becomes as shown in fig.4

$$I_5 = 8 \cdot 5 / (5+5) = 4A$$

### **Alternating current network**

#### **Alternating voltage and current:**

A voltage which change its polarity at regular intervals of time is called an alternating voltage. When an alternating voltage is applied in a circuit the

current flows first in one direction and then in the opposite direction. The direction of current at any instant depends upon the polarity of the voltage.

### **Generation of alternating voltage and current:**

- 1- By rotating a coil at constant angular velocity in a uniform magnetic field .
- 2- By rotating a magnetic field at constant angular velocity with stationary coil.

In either case ,the voltage obtained is called sinusoidal wave. The first method used to generate small voltage, while the second method is used to generate high voltage.

### **Waveform:**

The shape of the curve obtained by plotting the instantaneous values of voltage or current against time is called its waveform.

### **Instantaneous value:**

The value of an alternating quantity at any instant is called instantaneous value which are represented by e and i.

### **Cycle:**

On complete set of positive and negative values of an alternating quantity, and it is represented by T

### **Frequency:**

The number of cycles that occur in one second and it is measured in cycles /sec or Hz.

And it is represented by  $E_m$  for voltage and  $I_m$  for current.

### **Angular velocity:**

$$W=2\pi f \quad \text{rad/sec}$$

$$F=1/T$$

$$W=2\pi/T$$

Difference forms of alternating voltage and current:

$$e = E_m \sin \theta$$

$$i = I_m \sin \theta$$

$$E = E_m \sin \omega t$$

$$i = I_m \sin \omega t$$

$$E = E_m \sin 2\pi f t$$

$$i = I_m \sin 2\pi f t$$

$$E = E_m \sin 2\pi t / T$$

$$i = I_m \sin 2\pi t / T$$

**Ex.** An alternating current I is given by:

$$I = 141.4 \sin 314t$$

Find 1- the maximum value of current

2- the frequency

3- time period

4- the instantaneous value of current when t is 3ms.

1-  $I = 141.4 \text{ A}$

2-  $\omega = 314 = 2\pi f$

$$f = 314 / 2\pi = 50 \text{ Hz}$$

3-  $T = 1/f = 1/50 = 0.02 \text{ sec.}$

$$I = 141.4 \sin 314 * 3\text{ms} * 180 / \pi$$
$$= 114.35 \text{ A}$$

### **Values of alternating voltage and current:**

There are three values:

1- Peak value or (max value).

2- Average value or mean value.

3- R.M.S. value or effective value.

1- Peak value: it can be obtained from the oscilloscope.

2- Average value =(area under the curve)/base

Average value of the sinusoidal voltage is:

$$E_{av} = 0.636 E_m \quad \text{and} \quad I_{av} = 0.636 I_m$$

R.M.S. or effective value:

The effective value or R.M.S. value of an alternating current is that steady current (d.c) which when flowing through a given resistance for a given time produces the same amount of heat as produced by the alternating current when flowing through the same resistance for the same time.

R.M.S value of sinusoidal current :

$$I_{r.m.s} = 0.707 I_m \quad \text{and} \quad V_{r.m.s} = 0.707 V_m$$

**Form factor:**

Form factor =(R.M.S value)/ average value

$$\text{Form factor of sinusoidal wave} = 0.707 / 0.636 = 1.11$$

**Phasor diagram:**

Phasor diagram is the relationship between the applied voltage and the circuit current.

1- the length of the phasor diagram represent the maximum value of the alternating

Quantity in r.m.s and the angle with axis indicates the phasor of the alternating

Quantity.

2- A phasor diagram permits addition and subtraction of alternating quantity of the same kind (voltage and current).

**The case of a.c circuit containing resistance only.**

$$V = V_m \sin \omega t$$

nwt

$$I = I_m \sin \omega t$$

The applied voltage and the circuit current are in phase.

**The case of a.c circuit containing inductive only.**

$$V = V_m \sin \omega t$$

$$I = I_m \sin(\omega t - 90^\circ)$$

In a pure inductance, the current lags the voltage by  $\pi/2$  radians or 90

**The case of a.c circuit containing capacitive only.**

$$V = V_m \sin \omega t$$

$$I = I_m \sin(\omega t + 90^\circ)$$

In a pure capacitance, the current leads the voltage by  $\pi/2$  radians or 90

**Phasor diagram for R.L series circuit:**

$$V = V_m \sin \omega t$$

$$I = I_m \sin(\omega t - \theta)$$

**Phasor diagram for R.C series circuit:**

$$V = V_m \sin \omega t$$

$$I = I_m \sin(\omega t + \theta)$$

**Phasor diagram for R.L.C series circuit:**

$$V = V_m \sin \omega t$$

$$I = I_m \sin(\omega t \pm \theta)$$

**Phasor diagram for parallel a.c circuit:**

$$I \cos \theta = I_1 \cos \theta_1 + I_2 \cos \theta_2$$

$$I \sin \theta = I_1 \sin \theta_1 + I_2 \sin \theta_2$$

$$I = \sqrt{(I \cos \theta)^2 + (I \sin \theta)^2}$$

$$\tan \theta = I \sin \theta / I \cos \theta$$

**Instantaneous power:**

$$P_{av} = (I_{rms})^2 \cdot R$$

$$* V_{rms} \text{ Or } P_{av} = I_{rms}$$

$$P_{av} = (V_{rms})^2 / R$$

### In the case of capacitance:

$$P=0$$

### In the case of inductance:

$$P=0$$

### In the case of impedance:

$$P = V_{rms} \cdot I_{rms} \cdot \cos\theta$$

$\cos\theta$  is called the power factor and it is unitless.

$S = V_{rms} \cdot I_{rms}$  and is called the apparent power in volt ampere

$$Q = V_{rms} \cdot I_{rms} \cdot \sin\theta$$

Power factor : is the factor which must be multiplied to apparent power to obtain true power.

**Ex.:** A coil having a resistance of 7  $\Omega$  and inductance of 31.8mH connected to 230v , 50Hz supply.

Calculate:

1- The circuit current

- 2- The phase angle
- 3- The power factor
- 4- power consumed
- 5- apparent power
- 6- reactive power

$$\Omega XL = 2\pi f L = 2\pi * 50 * 31.8 * 10^{-3} = 10$$

$$Z = \sqrt{R^2 + XL^2} = \sqrt{7^2 + 10^2} = 12.2 \Omega$$

- 1-  $I = V/Z = 230/12.2 = 18.85A$
- 2-  $\theta = \tan^{-1} XL/R$   
 $= \tan^{-1} 10/7 = 55 \text{ lag}$
- 3-  $P.f = \cos 55 = 0.573 \text{ lag}$
- 4-  $P = VI \cos \theta = 230 * 18.8 * 0.573 = 2464.24 \text{ W}$
- 5-  $S = VI = 230 * 18.8 = 4335.5 \text{ W}$
- 6-  $Q = VI \sin \theta = 230 * 18.8 * \sin 55 = 3551.4 \text{ VAR}$

Lecture number:	4 <sup>th</sup> , 5 <sup>th</sup> and 6 <sup>th</sup> weeks
Lecture title:	Electrical technology
Lecturer name:	Safwan Assaf
Target group :	1 <sup>st</sup> stage
General objective of the lecture:	The student understands the basic concepts of Electrical technology
Behavioral objectives or learning outcomes:	<ul style="list-style-type: none"> <li>• Explain the principles that underlie the ability of various natural phenomena to deliver solar energy.</li> <li>• outline the technologies that are used to harness the power of solar energy</li> <li>• discuss the positive and negative aspects of solar energy in relation to natural and human aspects of the environment.</li> </ul>
Facilitation strategies used	Whiteboard + data show
Acquired skills	Learn about the Electrical technology
Approved measurement methods	Quiz+ Seminar+ Assignments

## معادلات تحويل دلتا إلى ستار

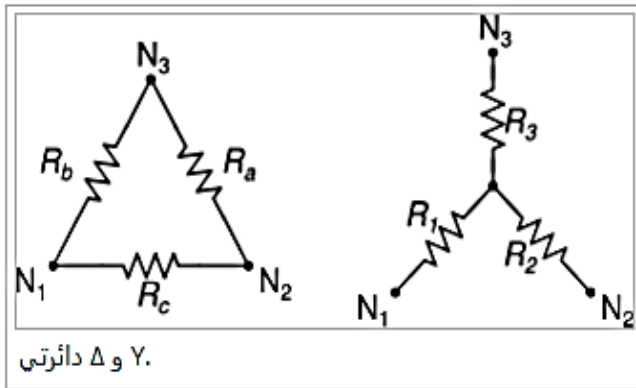

إلى Δ لتحويل العناصر  $\{R_a, R_b, R_c\}$  من الدائرة دلتا يتم ربط بداية كل عنصر ونهايته  $\{R_1, R_2, R_3\}$  في الدائرة ستار Δ: يكونوا مثلث  $N_1$  و  $N_2$  و  $N_3$  بالعقد. يمكن ملاحظة أن العقد

$$\begin{aligned} R_{\Delta}(N_1, N_2) &= R_c \parallel (R_a + R_b) \\ &= \frac{1}{\frac{1}{R_c} + \frac{1}{R_a + R_b}} \\ &= \frac{R_c (R_a + R_b)}{R_a + R_b + R_c} \end{aligned}$$

$\{R_a, R_b, R_c\}$ . للتبسيط، نجعل  $R_T$  هي حاصل جمع العناصر التالية

$$R_T = R_a + R_b + R_c$$

Δ: في الدائرة  $N_2$  والعقدة  $N_1$  المقاومة بين العقدة

$$R_{\Delta}(N_1, N_2) = \frac{R_c (R_a + R_b)}{R_T}$$

Y: تكون المقاومة المكافئة في الدائرة

$$R_Y(N_1, N_2) = R_1 + R_2$$

بالتالي:

$$R_1 + R_2 = \frac{R_c(R_a + R_b)}{R_T} \quad (1)$$

وبالمثل في حالة  $R(N_2, N_3)$ :

$$R_2 + R_3 = \frac{R_a(R_b + R_c)}{R_T} \quad (2)$$

وبالمثل أيضا في حالة  $R(N_1, N_3)$ :

$$R_1 + R_3 = \frac{R_b(R_a + R_c)}{R_T}. \quad (3)$$

وبالتالي يمكن استنتاج قيم  $\{R_1, R_2, R_3\}$  عن طريق عمليات الجمع والطرح

كالتالي

$$R_1 = \frac{R_b R_c}{R_T} \quad (4)$$

$$R_2 = \frac{R_a R_c}{R_T} \quad (5)$$

$$R_3 = \frac{R_a R_b}{R_T} \quad (6)$$

## معادلات تحويل ستار إلى دلتا

نجعل

$$R_T = R_a + R_b + R_c.$$

$\gamma$  من  $\Delta$  يمكن استخلاص معادلات

$$R_1 = \frac{R_b R_c}{R_T} \quad (1)$$

$$R_2 = \frac{R_a R_c}{R_T} \quad (2)$$

$$R_3 = \frac{R_a R_b}{R_T}. \quad (3)$$

بضرب كل معادلتين، يكون شكل المعادلات كالتالي

$$R_1 R_2 = \frac{R_a R_b R_c^2}{R_T^2} \quad (4)$$

بضرب كل معادلتين، يكون شكل المعادلات كالتالي:

$$R_1 R_2 = \frac{R_a R_b R_c^2}{R_T^2} \quad (4)$$

$$R_1 R_3 = \frac{R_a R_b^2 R_c}{R_T^2} \quad (5)$$

$$R_2 R_3 = \frac{R_a^2 R_b R_c}{R_T^2} \quad (6)$$

ثم جمع المعادلات، لتكون المعادلة كالتالي:

$$R_1 R_2 + R_1 R_3 + R_2 R_3 = \frac{R_a R_b R_c^2 + R_a R_b^2 R_c + R_a^2 R_b R_c}{R_T^2} \quad (7)$$

بأخذ  $R_a R_b R_c$  عامل مشترك في الطرف الأيمن، فتظهر  $R_T$  ثم اختصارها مع  $R_T$  الموجودة في المقام

$$\begin{aligned} R_1 R_2 + R_1 R_3 + R_2 R_3 &= \frac{(R_a R_b R_c) (R_a + R_b + R_c)}{R_T^2} \\ &= \frac{R_a R_b R_c}{R_T} \end{aligned} \quad (8)$$

بعد قسمة (8) على (1):

$$\begin{aligned} \frac{R_1 R_2 + R_1 R_3 + R_2 R_3}{R_1} &= \frac{R_a R_b R_c}{R_T} \frac{R_T}{R_b R_c} \\ &= R_a, \end{aligned}$$

بأخذ  $R_a R_b R_c$  عامل مشترك في الطرف الأيمن، فتظهر  $R_T$  ثم اختصارها مع  $R_T$  الموجودة في المقام

$$\begin{aligned} R_1 R_2 + R_1 R_3 + R_2 R_3 &= \frac{(R_a R_b R_c)(R_a + R_b + R_c)}{R_T^2} \\ &= \frac{R_a R_b R_c}{R_T} \end{aligned} \quad (8)$$

بعد قسمة (8) على (1):

$$\begin{aligned} \frac{R_1 R_2 + R_1 R_3 + R_2 R_3}{R_1} &= \frac{R_a R_b R_c}{R_T} \frac{R_T}{R_b R_c} \\ &= R_a, \end{aligned}$$

$R_b$  ,  $R_c$  وبالتالي نحصل على  $R_a$  في دائرة دلتا. وبالمثل قسمة (8) على (2) مرة وعلى (3) مرة أخرى لنحصل على

Lecture number:	7 <sup>th</sup> , 8 <sup>th</sup> and 9 <sup>th</sup> weeks
Lecture title:	Electrical technology
Lecturer name:	Safwan Assaf
Target group :	1 <sup>st</sup> stage
General objective of the lecture:	The student understands the basic concepts of Electrical technology
Behavioral objectives or learning outcomes:	<ul style="list-style-type: none"> <li>• Explain the principles that underlie the ability of various natural phenomena to deliver solar energy.</li> <li>• outline the technologies that are used to harness the power of solar energy</li> <li>• discuss the positive and negative aspects of solar energy in relation to natural and human aspects of the environment.</li> </ul>
Facilitation strategies used	Whiteboard + data show
Acquired skills	Learn about the Electrical technology
Approved measurement methods	Quiz+ Seminar+ Assignments

## AC CIRCUIT

The voltages of ac sources alternate in polarity and vary in magnitude and thus produce currents that vary in magnitude and alternate in direction.

Advantages of AC:

1. Electric generators that work by induction produce AC
2. Transformers use AC
3. Transformers can be used to step up and step down voltage to efficiently transmit electricity
4. Requires less wire
5. AC induction motors

### GENERATION OF ALTERNATING CURRENT OR VOLTAGE

To generate A.C current or voltage, must have rotating coil within a stationary magnetic field or by rotating a magnetic field within a stationary coil. The magnitude of e.m.f. generated in the coil depends upon the number of turns on coil, strength of magnetic field and the speed at which the coil or magnetic field rotates.

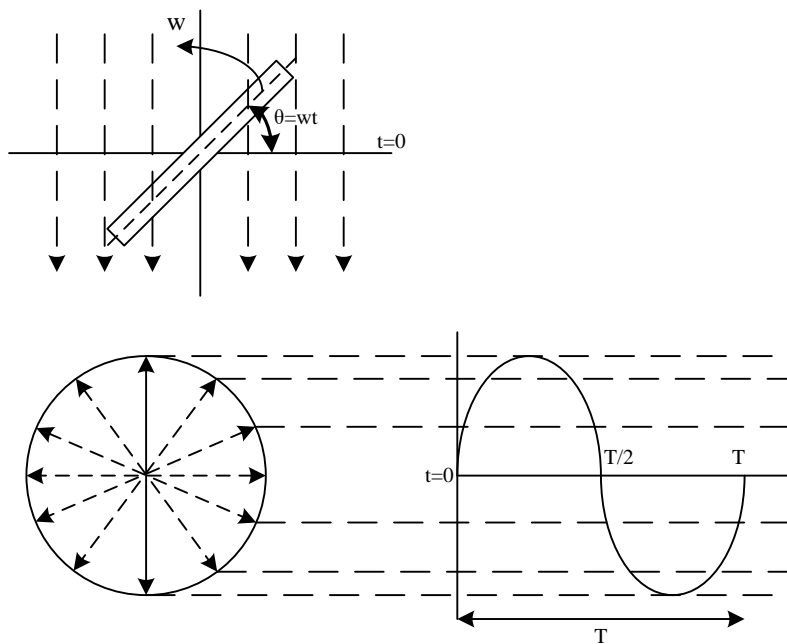

The voltage produced by this generator is

$$v = V_m \sin(\omega t) \text{ (V)}$$

where,  $V_m$  is the maximum coil voltage and

$\omega$ : angular velocity  $= 2\pi f = 2\pi/T$

$$v = V_m \sin(2\pi ft), \quad i = I_m \sin(2\pi ft)$$

One complete cycle corresponds to  $360^\circ$ .

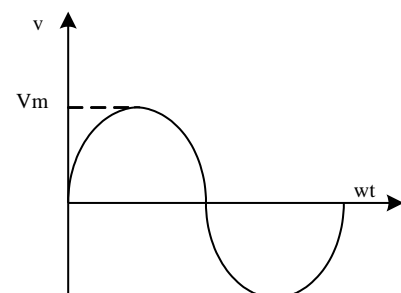

For resistive load, during the first half cycle, the source voltage is positive; therefore, the current is in the clockwise direction. During the second half-cycle, the voltage polarity reverses; therefore, the current is in the counterclockwise direction. Since current is proportional to voltage, its shape is also sinusoidal.

**Cycle:** when the signal goes through one complete set of positive and one complete set of negative values it is said to have complete one cycle.

**Periodic time (T):** represent the time needed to complete one cycle.

**Frequency (f):** which represents the number of cycles completed during one second of time. (Cycles Per Second)(Hz)

$$1 \text{ Hz} = 1 \text{ cycle per second} \quad F = \frac{1}{T}$$

Thus, the examples depicted in Figure below represent 1 Hz, 2 Hz, and 60 Hz respectively.

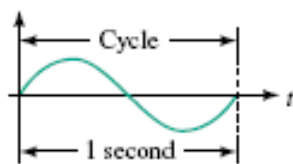

(a) 1 cycle per second = 1 Hz

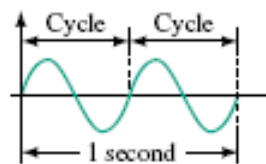

(b) 2 cycles per second = 2 Hz

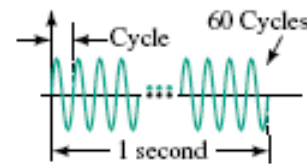

(c) 60 cycles per second = 60 Hz

Angular velocity ( $\omega$ ): is the speed of rotation of the angle measured in radians per second [rad/s],  $\omega = 2\pi f$

If the coil rotates through an angle of  $30^\circ$  in one second, for example, its angular velocity is  $30^\circ$  per second.

$$\theta = \omega t, \quad \omega = \theta/t, \quad \text{Angular velocity} = \frac{\text{distance(degrees or radians)}}{\text{time(seconds)}}$$

**Ex.1:** If the coil rotates at  $\omega = 300^\circ/\text{s}$ , how long does it take to complete one revolution?

**Sol.**

One revolution is  $360^\circ$ . Thus,

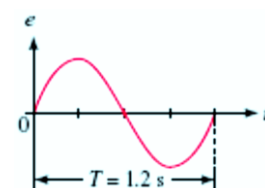

$$t = \frac{\theta}{\omega} = \frac{360}{300} = 1.2 \text{ s} = T$$

### Radian Measure

$$2\pi \text{ radians} = 360^\circ$$

To convert from degrees to radians, multiply by  $\pi/180$ , while to convert from radians to degrees, multiply by  $180/\pi$ .

$$\theta_{\text{radians}} = \frac{\pi}{180} * \theta_{\text{degrees}}, \quad \theta_{\text{degrees}} = \frac{180}{\pi} * \theta_{\text{radians}}$$

### H.W:

1. If  $w = 240 \text{ rad/s}$ , what are  $T$  and  $f$ ? How many cycles occur in  $27 \text{ s}$ ?
2. If  $56\,000$  cycles occur in  $3.5 \text{ s}$ , what is  $w$ ?

*Answers:*

1.  $26.18 \text{ ms}$ ,  $38.2 \text{ Hz}$ ,  $1031$  cycles
2.  $100.5 * 10^3 \text{ rad/s}$

**Ex.2:** An alternating current of frequency  $60 \text{ Hz}$  has a maximum value of  $120 \text{ A}$ . Write down the equation for its instantaneous value. Find the time taken to reach  $96 \text{ A}$  for the first time.

### Sol.

- 1)  $i = I_m \sin(2\pi ft) = 120 \sin(2\pi * 60t) = 120 \sin(120\pi t)$
- 2) when instantaneous value is  $96 \text{ A}$   
 $96 = 120 \sin(120\pi t)$   
 $t = 0.00246 \text{ s}$

**H.W.3:** For  $v = 170 \sin 2450t$ , determine  $v$  at  $t = 3.65 \text{ ms}$  and show the point on the  $v$  waveform.

**Ex.3:** An alternating current of frequency  $50 \text{ Hz}$  has a maximum value of  $100 \text{ A}$ . Calculate: 1) its value at  $(1/600) \text{ sec.}$  after the instant the current is zero. 2) in how many seconds after the zero value the current attains the value of  $86.6 \text{ A}$ .

### Sol.

- 1)  $i = 100 \sin(2\pi 50t) = 100 \sin(314/600) = 50 \text{ A}$
- 2)  $86.6 = 100 \sin(314t)$   
 $t = 1/300 \text{ sec.}$

## AVERAGE VALUE

$$F_{av.} = \frac{1}{T} \int_0^T f(t) dt$$

For sinusoidal current or voltage

The average value of a sine wave over complete cycle is zero.

$$v = V_m \sin(\omega t)$$

taking for half cycle

$$E_{av.} = \frac{\text{area of first half cycle}}{\pi} = \frac{1}{\pi} \int_0^{\pi} v d\omega t$$

$$\frac{1}{\pi} \int_0^{\pi} V_m \sin(\omega t) d\omega t = \frac{V_m}{\pi} [-\cos(\omega t)]_0^{\pi} = 0.637 V_m$$

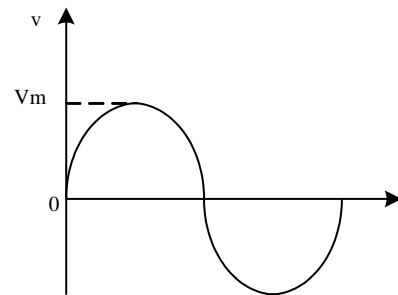

Similarly,

$$I_{av.} = 0.637 I_m \quad \text{H.W.}$$

**Ex.4:** Suppose the saw tooth waveform in Fig. represent a voltage. Find its average value, assuming it's amplitude is 10 V and it's period is 2s.

**Sol.**

$$\frac{y - y_1}{x - x_1} = \frac{y_2 - y_1}{x_2 - x_1}$$

$$\frac{y - 0}{x - 0} = \frac{10 - 0}{2 - 0} \quad y = 5x, \quad V = 5t,$$

$$\text{Average} = \frac{1}{2} \int_0^2 5t dt =$$

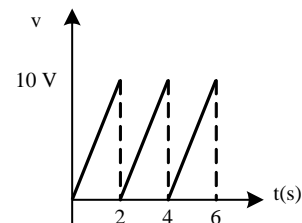

**H.W.4:** Find the average value of the signal shown.

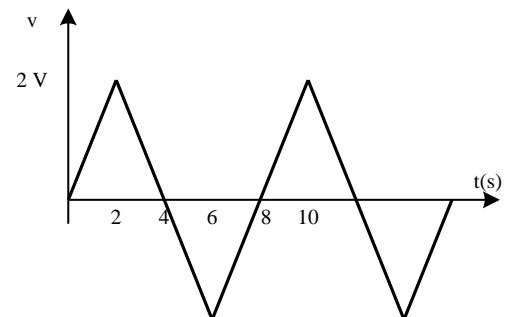

$$\text{Average value} = \frac{\text{algebraic sum of area under the curve}}{\text{length of the curve}}$$

## R.M.S(ROOT MEAN SQUARE) (effective) value

The effective value of an A.C current is measured in terms of a DC current that produces the same heating effect in the same resistance.

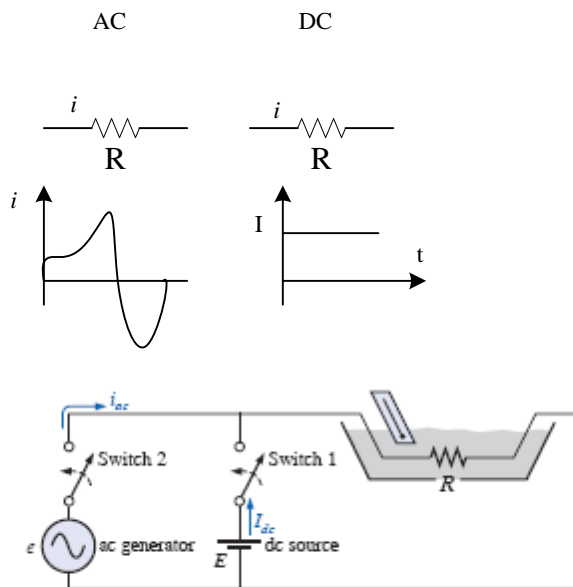

FIG. 13.52

An experimental setup to establish a relationship between dc and ac quantities.

The power delivered by the ac supply at any instant of time is

$$P_{ac} = (i_{ac})^2 R = (Im \sin (wt))^2 R = (Im^2 \sin^2(wt))R$$

but

$$\sin^2 (wt) = \frac{1}{2} (1 - \cos(2wt)) \quad (\text{trigonometric identity})$$

Therefore,

$$P_{ac} = Im^2 \left[ \frac{1}{2} (1 - \cos(2wt)) \right] R$$

$$P_{ac} = \frac{Im^2 R}{2} - \frac{Im^2 R}{2} \cos(2wt)$$

The *average power* delivered by the ac source is just the first term, since the average value of a cosine wave is zero

$$P_{av.(ac)} = P_{dc} \quad \frac{I_m^2 R}{2} = I_{dc}^2 R \quad \text{and } I_m = \sqrt{2} * I_{dc}$$

$$\text{Or } I_{dc} = I_m / \sqrt{2} = 0.707 I_m$$

**The equivalent dc value of a sinusoidal current or voltage is  $1/\sqrt{2}$  or 0.707 of its maximum value.**

The equivalent dc value is called the **effective value** of the sinusoidal quantity.

$$F_{R.M.S} = \sqrt{\frac{1}{T} \int_0^T f^2(wt) dwt} = \sqrt{\frac{1}{2\pi} \int_0^{2\pi} i^2 dwt} = \sqrt{\frac{\text{area}(i^2(t))}{T}}$$

To find the effective value for sinusoidal current or voltage

$$I_{R.M.S} = \sqrt{\frac{1}{\pi} \int_0^{\pi} I_m^2 \sin^2(wt) dwt} = \sqrt{\frac{I_m^2}{2\pi} \int_0^{\pi} (1 - \cos(2wt)) dwt}$$

$$I_{R.M.S} = \sqrt{\frac{I_m^2}{2\pi} \left[ wt - \frac{1}{2} \sin(2wt) \right]_0^{\pi}} = \frac{I_m}{\sqrt{2}}$$

$$\text{Similarly, } E_{R.M.S} = \frac{E_m}{\sqrt{2}} \quad \text{H.W.}$$

For instance, normal AC in Iraq is 220 Volts AC with frequency 50 Hz. The RMS voltage is 240 volts, so the peak value  $V_m = V * \sqrt{2} = 340$  volts. So the active wire goes from +311 volts to -311 volts and back again 50 times per second.

**Ex.:** The 120-V dc source of Fig. (a) delivers 3.6 W to the load. Determine the peak value of the applied voltage ( $E_m$ ) and the current ( $I_m$ ) if the ac source is to deliver the same power to the load.

**Sol.**

$$P_{dc} = I_{dc} V_{dc} \quad I_{dc} = \frac{P_{dc}}{V_{dc}} = \frac{3.6}{120} = 30 \text{ mA}$$

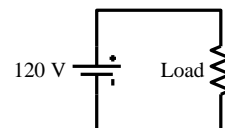

$$I_m = \sqrt{2} I_{dc} = 1.414 * 30 * 10^{-3} = 42.42 \text{ mA}$$

$$E_m = \sqrt{2} E_{dc} = 1.414 * 120 = 169.68 \text{ V}$$

**Ex.:** Find the effective or rms value of the waveform of Fig.

Sol.

$$V_{rms} = \sqrt{\frac{9 \cdot 4 + 1 \cdot 4}{8}} = 2.236 \text{ V}$$

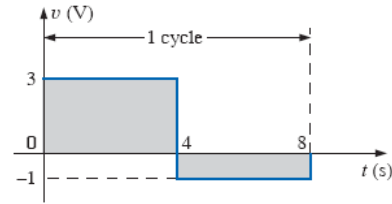

**Ex.5:** Determine the average and r.m.s values of sinusoidal current of peak value 40 A.

Sol.

$$I_{av.} = 40 \cdot 0.637 = 25.48 \text{ A}$$

$$I_{r.m.s} = \frac{40}{\sqrt{2}} = 28.28 \text{ A}$$

**Ex.6:** What is the equation of sinusoidal current of 25 Hz freq. having an r.m.s. value of 40 A.

Sol.

$$I_m = \sqrt{2} I_{r.m.s} = 40 \cdot \sqrt{2} \text{ A}$$

$$I = I_m \sin(\omega t) = 40 \sqrt{2} \sin(2\pi \cdot 25t) =$$

**H.W.5:** Determine the r.m.s value of the signals for one cycle.

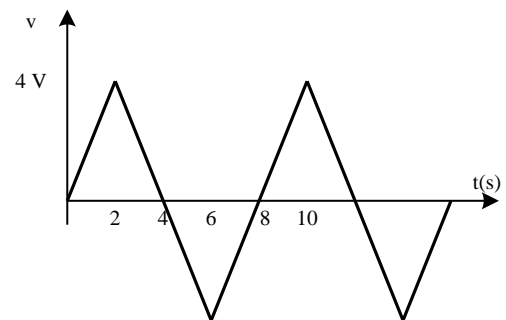
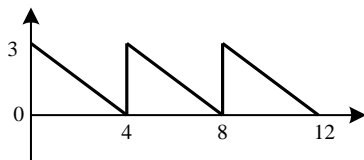

### **FORM FACTOR (KF)**

Is the effective over average value

For sinusoidal wave

$$\text{Form factor} = kf = \frac{V_{eff.}}{V_{av.}} = \frac{0.707V_m}{0.637V_m} = 1.11$$

Note: effective value and average value do not effect by frequency of the signals.

For example  $i_1 = 12 \sin(\omega t)$ ,  $i_2 = 12 \sin(3\omega t)$

$$I_{eff.1} = I_{eff.2} = 0.707 * 12 = 8.484 \text{ A}$$

$$I_{av.1} = I_{av.2} = 0.637 * 12 =$$

**H.W.6:** Find the form factor of the following waveform.

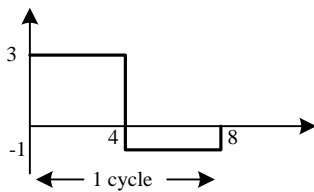

### TERMINOLOGY

Instantaneous value	$i$
	$v$
R.M.S value	$I$
	$V$
Maximum value	$I_m$
	$V_m$

### **RESPONSE OF BASIC $R$ , $L$ , AND $C$ ELEMENTS TO A SINUSOIDAL VOLTAGE OR CURRENT**

#### **Resistor**

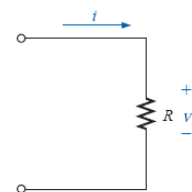

$$i = \frac{v}{R} = \frac{V_m \sin \omega t}{R} = \frac{V_m}{R} \sin \omega t = I_m \sin \omega t$$

Where

$$I_m = \frac{V_m}{R}$$

In addition, for a given  $i$ ,

$$v = iR = (I_m \sin \omega t)R = I_m R \sin \omega t = V_m \sin \omega t$$

Where

$$V_m = I_m R$$

*The voltage and current are in phase.*

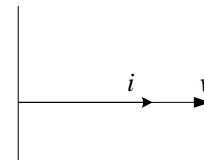
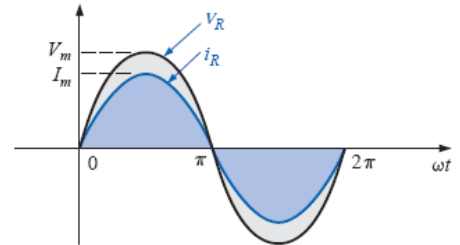

## Inductor

$$v_L = L \frac{di_L}{dt}$$

and, applying differentiation,

$$\frac{di_L}{dt} = \frac{d}{dt}(I_m \sin \omega t) = \omega I_m \cos \omega t$$

Therefore,

$$v_L = L \frac{di_L}{dt} = L(\omega I_m \cos \omega t) = \omega L I_m \cos \omega t$$

or

$$v_L = V_m \sin(\omega t + 90^\circ)$$

Since  $\sin(\omega t + 90^\circ) = \cos \omega t$

where

$$V_m = \omega L I_m$$

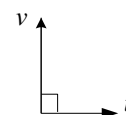
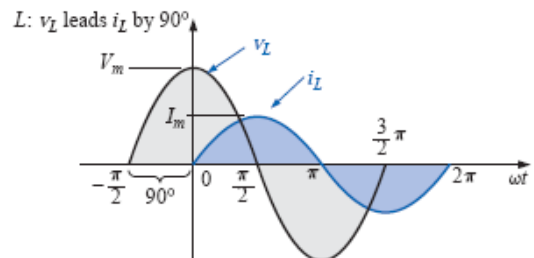
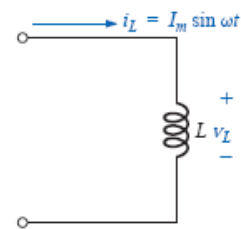

The current wave lags the voltage wave by 90°

$$\frac{V_m}{I_m} = j\omega L = X_L \text{ ohms}$$

### Capacitor

$$i_C = C \frac{dv_C}{dt}$$

and, applying differentiation,

$$\frac{dv_C}{dt} = \frac{d}{dt}(V_m \sin \omega t) = \omega V_m \cos \omega t$$

Therefore,

$$i_C = C \frac{dv_C}{dt} = C(\omega V_m \cos \omega t) = \omega C V_m \cos \omega t$$

or

$$i_C = I_m \sin(\omega t + 90^\circ)$$

$$i_C = j\omega C V_m \sin(\omega t)$$

where

$$I_m = j\omega C V_m$$

$$\frac{V_m}{I_m} = \frac{1}{j\omega C} = X_C \text{ ohms}$$

The current wave leads the voltage wave by 90°

or the voltage wave lags the current wave by 90°

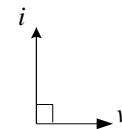
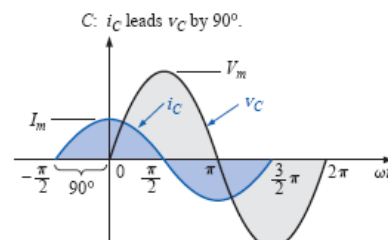
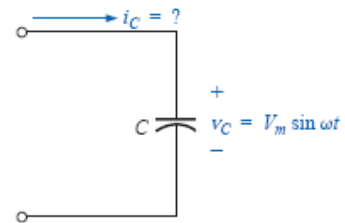

### Resistor



Resistance

$$V = IR$$

### Capacitor



Capacitive reactance

$$V = I X_C$$

Impedance  
 $Z \equiv V/I$

